

Thru Floor Core Hole Specification For Contractors

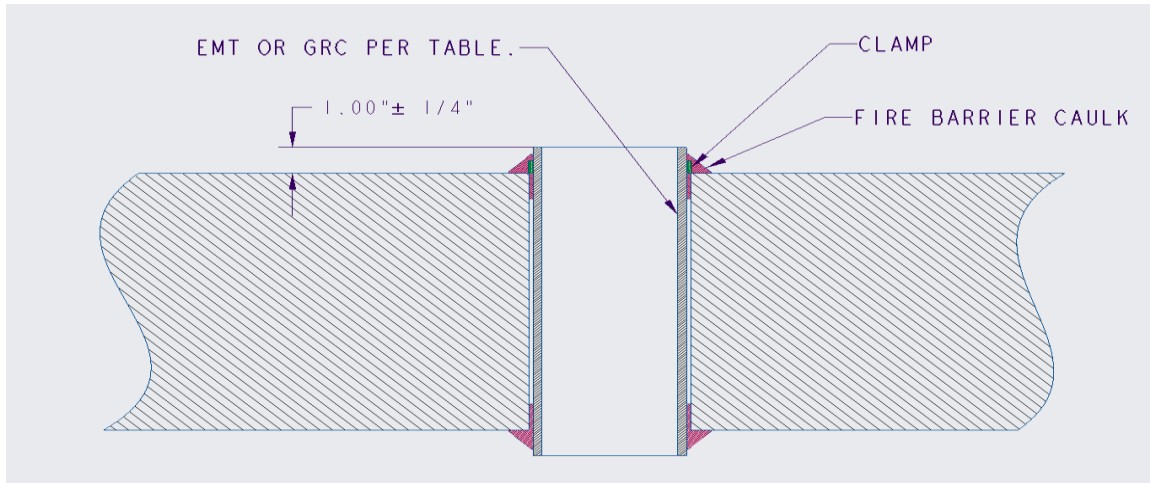

Core Hole Sizing Table

SLEEVE ID SIZE	SLEEVE TYPE	CORE HOLE SIZE
3"	EMT	3 ½"
4"	EMT	4 ½"
5"	GRC	6"
6"	GRC	7"

Location:

- RT will mark desired locations.
- Depending on the building, floor scanning might have to be performed before coring.
- Upon scanning, if the coring is not permitted at marked location, RT and the contractor will determine the best new location option.

Size:

- Core holes based on EMT size information provided by RT.

Installation:

- Install the EMT, secure with a clamp and fill all gaps with fire barrier caulk.